



RELATIONSHIP BETWEEN OFFICE FACTORS AND WINDOW VIEW FACTORS IN SHARED ROOM AND OPEN-PLAN OFFICES

Mercy Inikpi Achoba^{1*}, Roshida Abdul Majid², Cyril Obinna³

¹ Architecture Programme, Faculty of Built Environment and Surveying, Universiti Teknologi Malaysia, Johor, Malaysia

Email: mercy.inikpi.achoba@graduate.utm.my

² Architecture Programme, Faculty of Built Environment and Surveying, Universiti Teknologi Malaysia, Johor, Malaysia

Email: b-roshida@utm.my

³ Department of Architectural Technology, Federal Polytechnic Idah, Kogi, Nigeria

Email: cyrister37@yahoo.com

* Corresponding Author

Article Info:

Article history:

Received date: 15.12.2021

Revised date: 13.01.2022

Accepted date: 25.02.2022

Published date: 08.03.2022

To cite this document:

Achoba, M. I., Majid, R. A., & Obinna, C. (2022). Relationship Between Office Factors And Window View Factors In Shared Room And Open-Plan Offices. *Journal of Tourism Hospitality and Environment Management*, 7 (27), 438-449.

DOI: 10.35631/JTthem.727035.

This work is licensed under [CC BY 4.0](https://creativecommons.org/licenses/by/4.0/)



Abstract:

An office is a place where office task is carried out. An important building component that provides a view to the outside is the window. This paper aims to investigate the effect of office and view factors on occupants' satisfaction. The research uses a cross-sectional survey method, data was collected from five offices in Kogi State in Nigeria with a total of 267 respondents. The purposive sampling method was used because it was specifically for occupants of shared-room offices and open-plan offices. The analysis was performed using SPSS Version 23 and AMOS Version 22 for modelling. Seven salient factors were identified to be interrelated in the relationship model. The results revealed a valid model and the effect of each construct on occupants' satisfaction was moderate. The overall squared multiple correlation value is moderate. The study extends the existing knowledge of the relationship between office and window view factors on occupants' satisfaction. Also, it provides suggestions for building stakeholders such as Architects, Builders, Interior Designers, and Facility Managers that can be applied to improve the satisfaction level of office space users, thereby creating a sustainable office environment.

Keywords:

View, Window, Office, Occupants' Satisfaction

Introduction

An office building is majorly to provide a workspace and a supportive environment for its occupants. Office space has been continuously linked with administrative and intellectual output. The increasing use of automation in the manufacturing sector has led to a shift of jobs towards the service industry (WCED, 1987), thereby creating a repositioning of the economy (Morrison & Macky, 2016). Physical office work in a production environment has metamorphosed to deskwork and knowledge excellent work environment over the past years (Kang, Ou, & Mak, 2017; Van der Meiden, Kok, & Van der Velde, 2019). Office workspace now provides a flexible environment with activities contrary to the traditional fixed and passive style (Ali, Chua, & Lim, 2015). The consistent venture for improved handling of information and exceptional productivity is the reason for these changes in workspaces through the years.

Classification of Offices

An office layout refers to the physical office space, and offices are classified based on their functional features and layout. The different categories of offices are single-cell, shared-room, open-plan, flex, and combi office (Danielsson, Wulff, & Westerlund, 2013; Danielsson & Bodin, 2008; Danielsson, Bodin, Wulff, & Theorell, 2015; De Been & Beijer, 2014; Seddigh, Berntson, Bodin, & Westerlund, 2014). The single-cell office which is also known as the private office refers to a single room office that is mostly occupied by one person. The single-cell office is commonly an enclosed area having a window. The office spaces that are occupied by two or three occupants' are referred to as the shared room offices. Access to individual windows, privacy or visual screens may not be provided for in the shared room and open-plan office (Danielsson & Bodin, 2008). The open-plan offices have open layouts with fixed workstations that may have an inner wall separating the office space. The open-plan office is sub-divided into three types; the small open-plan, medium-sized open-plan, and the large open-plan. The number of employees in the office determines the office type, the small open-plan consist of four to nine people, the medium-sized open-plan office consist of ten to twenty-four people, while the large open-plan office consists of twenty-five or more people (Danielsson & Bodin, 2008). The flex- office is an open-plan space that allows not more than seventy per cent of the workers to be in the office altogether, while the combi office does not have defined spatial areas therefore the workers of this office type have access to individual workstation spaces for collaborative work (Danielsson & Bodin, 2008).

The outdoor environment of an office and the views accessed through the window which constitute part of the workplace physical environment is an important benefit as regards occupants' satisfaction and work performance that has been ignored (Lottrup et al., 2015). From the office definitions given, the focus of this paper will be on the shared-room and small open-plan offices.

Window view

One of the requirements for an office building is the provision of windows. A window is a conspicuously attractive element in an office due to its daylight and view to the outside functions (Marty, Marty, Fontoynt, & Christoffersen, 2003). The window element is a building component that allows visual contact from the inside to the outside world (Hellinga, 2013), enabling a visual connection with the external atmosphere (Fontenelle, Eurico, & Bastos, 2014). The principal functions of windows are ventilation, lighting, and viewing (Hellinga, 2013). The window is an important physical building element that solves the psychological demands of occupants' by providing a view that connects them to the outside.

The intricacy of the interactions and attachment to windows by humans ought to be understood for an effective maximization of window benefits for different user groups (Fontenelle & Bastos, 2014). Research on windows have shown that comfort ratings recorded from building occupants' that have access to windows is better than those who have their seating located positioned away from windows, this result applies to various types of buildings. Yildirim, Akalin-Baskaya, & Celebi, (2007) in their study found that the satisfaction of an occupant is highly influenced by the distance of the window from their seats.

A view in office settings can be defined as the part of the immediate surrounding that is continuously seen by the employee. Research has shown that window views and connections to the outside environment are of utmost value which is not just based on preference (Heerwagen & Orians, 1986), but on the occupants' health and well-being (Küller & Lindsten, 1992; Mangkuto, Rohmah, & Asri, 2016; O'Brien & Gunay, 2014). According to Lottrup et al., (2015), the benefits of natural settings are theoretically explained based on evolutionary and cognitive standpoint. In general, one of the most likely thrilling window function is the view (Aries et al., 2010; Ozdemir, 2010), the reason is that access to view connects the outside to the inside (Salonen et al., 2014). Office occupants' usually spend a lot of their time in the office staying indoors on account of working culture or the belief of being too busy (Lottrup et al., 2015). Occupants' of offices mostly spend at least eight hours in the office daily, and the office environment is often characterized as a stressful and fatiguing environment with fewer features of nature, and usually tension-filled (Chang & Chen, 2005). Previous studies show that the presence of a window in an office space serves more functions than just aesthetics. The connection to views has positive psychological effects on the occupants'. The window view acts as a micro-restorative setting because it allows for micro-breaks whenever the occupants' attention is drawn to the view (Kaplan, 1995). According to research, a glance at the outside greenery via a window brings about a heartening psychological outcome, also the rate of healing is improved because of having windows in the space (Herzog, Kaplan, & Kaplan, 1976; R. Kaplan, 1993; Ulrich et al., 1991). Window views can be beautiful, charming, captivating and allow a swift break from the office activity (Leslie, 2003).

Occupants' Satisfaction

Cambridge dictionary defines satisfaction as an emotion that is pleasant. It is a state whereby the needs or expectations are fulfilled or having nothing to complain about (Kwon, Remøy, & Bogaard, 2019). According to Samani, (2015), occupants' dissatisfaction may also arise from physical office conditions such as the orientation of façade, work desk location, or office layout. Occupants' satisfaction in the office is hinged on the window distance from the workspace and the nature of the task carried out (Kwon et al., 2019). In a nutshell, the view from the window is linked to occupants' satisfaction within an enclosed space (Konstantzos et al., 2015).

This study seeks to investigate the relationship of office factors and window view factors on occupants' satisfaction. The office factors and view factors considered for the study were based on Hartig, Mang, & Evans, (1991) statement that windows are necessary to provide the occupants with a visual linkage to the view outside for speedy recovery from stress. The office is made up of interconnection that links the occupants' and the work environment. Based on previous studies, the constructs used for this study are office factors; window distance, seating arrangement, room height, and office size, while the view factors are; view content, and view satisfaction. The occupants' satisfaction is measured using five items.

Aim and Scope

This study aims to investigate the effect of office and window view factors on occupants' satisfaction particularly in shared-room and open-plan offices within Kogi State of Nigeria, using Structural Equation Modelling. Thus, the data was collected specifically from office occupants' that occupied a shared room or an open-plan office in Government office buildings.

The study area is Kogi State which is situated in Nigeria.

The following hypotheses are formulated based on the literature reviewed.

H1- Office factors have a significant and positive influence on Occupants' satisfaction

H2- View factors have a significant and positive influence on Occupants' satisfaction

Materials and Methods

The research made use of the survey method whereby questionnaires were used for the research. The questions were adapted from previous research; Hellinga, (2013), Aries et al., (2010), and Dogrusoy & Tureyen, (2007). A team of experts consisting of three Architects, two Facility Managers, a Building Technologist, and two Landscape Architects took care of the content validity. The questionnaire is divided into four sections, namely the demographic data, office factors, windows and view factors and occupants preferences.

The survey is a cross-sectional survey whereby closed-ended questionnaires were distributed across five Government buildings in Kogi State. The purposive sampling method was used to specifically distribute the questionnaire to only occupants' of shared-room and open-plan office types. The 5-point Likert scale was used to get data from the respondents. A total of 350 questionnaires were administered, however, 331(94%) questionnaires were brought back. Consequently, questionnaires with an uncompleted response and missing data of more than 10% were not used for the analysis, therefore 267 valid questionnaires were used for the analysis. As stated by Awang, (2015), Hair et al., (2011) opine that a minimum sample size of 200 is acceptable.

Data Analysis of the Survey

The research was based on the valid 276 responses hence Structural Equation Modelling (SEM) was used for the inferential analysis. SEM is applicable with a sample size of at least 200 normally distributed data (Hox & Bechger, 1999). SEM comprises two components namely; the measurement model and the structural model. Confirmatory Factor Analysis (CFA) is a vital aspect used to test the fitness of data for the hypothesized model (Chong, Nazim, & Ahmad, 2014). In this study, the Statistical Package for Social Science (SPSS) version 23 was applied for the preliminary analysis while AMOS 22.0 version was the modelling tool.

Demographics of Respondents

The gender of the respondents had male (62.2%) and female (37.8%). The ages were classified as less than 30years (43.8%), 31-40 years (28.5%), 41-50 years (21.0%), 51-60 years (8.2), and above 60 years (1.1%). The Educational qualification showed that the majority of the respondents have acquired Tertiary Education and other higher qualifications; Secondary Education (2.2%), Tertiary Education (42.7%), Bachelor's Degree (41.6%), and Master's Degree (13.1%). Most of the respondents have served in their organisations for more than five years; less than 5 years is 37.1% while the summary of 5 years and above is 62.9%.

Kaiser-Meyer-Olkin and Bartlett's Test

SPSS version 23 was used for the analysis, it showed a Kaiser-Meyer-Olkin (KMO) and Bartlett's Test of Sphericity results of .000 is significant and the .840 value indicates that the data set is suitable and acceptable as the correlation matrix is not individualistic. Pallant, J. (2016) cited that Kaiser, 1970 suggests that having values of .6 and above is a good indication that the factor analysis is appropriate.

Construct Reliability

The Confirmatory Factor Analysis carried out using Analysis of Moment Structures (AMOS) software version 22. A fundamental requirement of using AMOS software is that the reliability and validity test is first carried out before proceeding to use the Structural Equation Modelling (SEM). The reliability assessment for the measurement model was done using the criteria for Composite Reliability (CR) and Average Variance Extracted (AVE). The CR and AVE result for each construct and are all above the required minimum value of 0.6 and 0.5 respectively (Awang, 2015). The total number of latent constructs is seven.

Construct Validity

The Confirmatory Factor Analysis (CFA) validating procedure was used, consequently, items with low factor loadings were deleted to achieve acceptable Fitness Indexes. The following items were deleted in the course of the individual pool of the CFA; WDB6, SAB6, VSC4, and CVC2. The identified pairs of unneeded items through Modification Indices (MI) were constrained using Covariation. The variables that resulted in Covariation are WDB2-WDB3, SAB2-SAB4, FHB1-FHB5, and VSC3-VSC6. Table 1 shows the results of the reliability and validity analysis. The model fitness of the collected data is achieved by making use of not less than one Fitness Index from each of the three groupings of the model fit (Holmes-Smith, 2006; Hooper, Coughlan, & Mullen, 2008). The Absolute fit category is made up of the Chi-square, Goodness of Fit Index (GFI), Root Mean Square Error of Approximation (RMSEA); the Incremental fit group comprises of Adjusted Goodness of Fit Index (AGFI), Comparative Fit Index (CFI), Bentler Bonett Normed Fit Index (NFI), and the Tucker-Lewis Index (TLI); while the third group is the Parsimonious fit (Chisq/df). Table 2 shows the results of the Fitness indices. The entire fitness indices point out acceptable values; CFI is 0.958, IFI is 0.958, TLI is 0.943, P is 0.000, RMSEA is 0.055, and with a ChiSq/df = 1.478. Based on the studies, if the figures of TLI, CFI, and IFI, are close to 0.95, meaning the model is considered a good fit (Bentler & Bonett, 1980), the Measurement model of this study is considered to be good.

Table 1: Results of Reliability and Validity Analysis

Constructs	Items	List of Items	Factor loading	Composite Reliability (CR) Above 0.6	Average Variance (AVE) Above 0.5
Office factors (OFAC)	WDB (Window distance)	WDB1	.97	0.930	0.733
		WDB2	.95		
		WDB3	.71		
		WDB4	.63		
		WDB5	.96		
	SAB (Seating arrangement)	SAB1	1.00	0.962	0.836
		SAB2	.77		
		SAB3	.96		
		SAB4	.85		
		SAB5	.97		
	FHB (Room height)	FHB1	.92	0.975	0.868
		FHB2	.91		
		FHB3	.97		
		FHB4	.97		
		FHB5	.82		
		FHB6	.99		
	OSB (Office size)	OSB1	.88	0.946	0.743
		OSB2	.83		
OSB3		.87			
OSB4		.87			
OSB5		.82			
OSB6		.90			
View factors (VIEF)	CVC (View content)	CVC1	.81	0.905	0.705
		CVC3	.85		
		CVC4	.76		
		CVC5	.93		
		VSC (View satisfaction)	VSC1		
	VSC2	.62			
	VSC3	.74			
	VSC5	.92			
	VSC6	.79			
Occupants' satisfaction (SAT)	SAT (Occupants' satisfaction)	SAT1	.88	0.932	0.733
		SAT2	.96		
		SAT3	.84		
		SAT4	.79		
		SAT5	.80		

Source: (Authors Field Work)

Table 2: Fitness Indices Result for the Measurement Model

Category's Name	Parsimonious Fit			Absolute fit	Incremental fit	Incremental fit	Absolute fit
	Chi-square	df	Chis q/df	CFI	IFI	TLI	RMSEA
Acceptance level	Chisq/ <3.0			CFI >0.90	IFI >0.90	TLI >0.90	RMSEA <0.08
Initial value	895.848	606	1.478	.958	.958	.943	.055

Source: (Authors Field Work)

Structural Model

The structural model is used for SEM analysis, it represents the existing relationships between the latent constructs. The two exogenous constructs VIEF and OFAC as shown in Figure 1 reveal that correlation is below 0.85 which means the constructs are not redundant. Table 3 shows the fitness indices results for the Structural model. The overall result had the following values: Chi-square= 1126.430, df =589, Ratio =1.912, CFI = .952, IFI= .952, TLI= .948, RMSEA= .059. The list of factor loadings and also, the validity of the office and window view constructs all have acceptable CR and AVE values.

Table 3: Fitness Indices Result for the Structural Model

Category's Name	Parsimonious Fit			Absolute fit	Incremental fit	Incremental fit	Absolute fit
	Chi-square	df	Chis q/df	CFI	IFI	TLI	RMSEA
Acceptance level	Chisq/ <3.0			CFI >0.90	IFI >0.90	TLI >0.90	RMSEA <0.08
Initial value	1126.430	589	1.912	.952	.952	.948	.059

Source: (Authors Field Work)

Discussion of Findings

Figure 1 is the outcome of the structural model. It reveals the interaction between all the constructs. The squared multiple correlations with R^2 as the value and standard regression weight were used for this research because of its benefit of clear and acceptable interpretation of the entire interrelationships existing in the model. The model is made up of thirty-six items, and each item has a factor loading that is above the required 0.6 and each of the R^2 value is above the required minimum value of 0.4. The standardized beta estimate for the effect of view factors (VIEF) on occupants' satisfaction is 0.53, while the standardized beta estimate for office factors is 0.43. The value of the correlation between the two exogenous constructs VIEF and OFAC is 0.36 which means that redundancy is non-existent between the construct and also, discriminant validity has been achieved.

The factor loadings are all positive with high significant values except for VIEF< -- >VSC that is not significant and has a negative factor loading value of -0.02. This means that the regression weight for OFAC in the prediction of the followings paths are all significantly different from zero at the 0.001 level; OFAC< -- >WDB, OFAC< -- >SAB, OFAC< -- >FHB, OFAC< --

>OSB, OFAC< -- >SAT, and SAT< -- >VIEF, while the regression weight for VIEF in the prediction of VSC is not significantly different from zero at the 0.05 level. The R^2 for OFAC constructs revealed WDB (0.33), SAB (0.36), FHB (0.50), and OSB (0.46) while the VIEF constructs revealed CVC (0.57), and VSC (-0.02). Also, the coefficient of determination R^2 reveals a value of 0.63. This value shows that the contribution of VIEF and OFAC constructs in estimating SAT is 63%, this overall value is an indication the model is good.

Table 4 shows that the regression weight estimate of SAT< -- OFAC is 0.698, has a Standard Error (S.E.) of about 0 .047 and the Critical Ratio (C.R.) is 14.902 standard errors above zero. Also, the regression weight estimate of SAT< -- VIEF is 0.617, has a Standard Error (S.E.) of about 0 .079 and the Critical Ratio (C.R.) is 7.797 standard errors above zero. The results reveal that both paths have a positive relationship. It shows that the study hypotheses both have positive effects on occupants' satisfaction (SAT). Hence, the hypotheses are both supported.

Hypotheses	Estimate	S.R	C.R	P
SAT< -- >OFAC	.698	.047	14.902	***
SAT< -- >VIEF	.617	.079	7.797	***

Source: (Authors Field Work)

Table 4: Significant Effect of Office Factors (OFAC) and Windows View (VIEF) Factors on Occupants' Satisfaction (SAT)

The model in Figure 1 shows the effect of office factors and window view factors on occupants' satisfaction based on the data retrieved from respondents in Kogi State that occupy shared-room and open-plan office layout. The output shows that even though the model has an overall good value the aspect of view satisfaction is still very poor. The view satisfaction (VSC) which is a sub-construct of view factors (VIEF) indicates that what is viewed by the office occupants' has a negative effect on their level of satisfaction. Furthermore, the seating arrangement (SAB) and window distance (WDB) with R^2 of .13 and .11 respectively indicates that these factors are not favourable to most of the occupants. These findings are in line with some past studies which opine that what is viewed through a window is also important and not just having a window present in the space (Ozdemir, 2010; Kaplan, 1993). A study carried out among office occupants revealed that employees who had access to even a bit of nature outside the building through the window had significant satisfaction ratings than those who did not have access to surrounding nature (Kaplan, 1993). The relationship between view satisfaction and view factors in this study is negative, although that of view content and view factors is positive, the weak values of seating arrangement and window distance indirectly affect view satisfaction negatively. These factors are determinants of occupants' satisfaction according to Charles & Veitch (2002), Yildirim et al (2007). This is in line with previous studies whose findings show that offices vary in terms of satisfaction prospects and that several perceived physical properties of offices are associated with satisfaction (Chang & Chen, 2005; Galasiu & Veitch, 2006; Ozdemir, 2010).

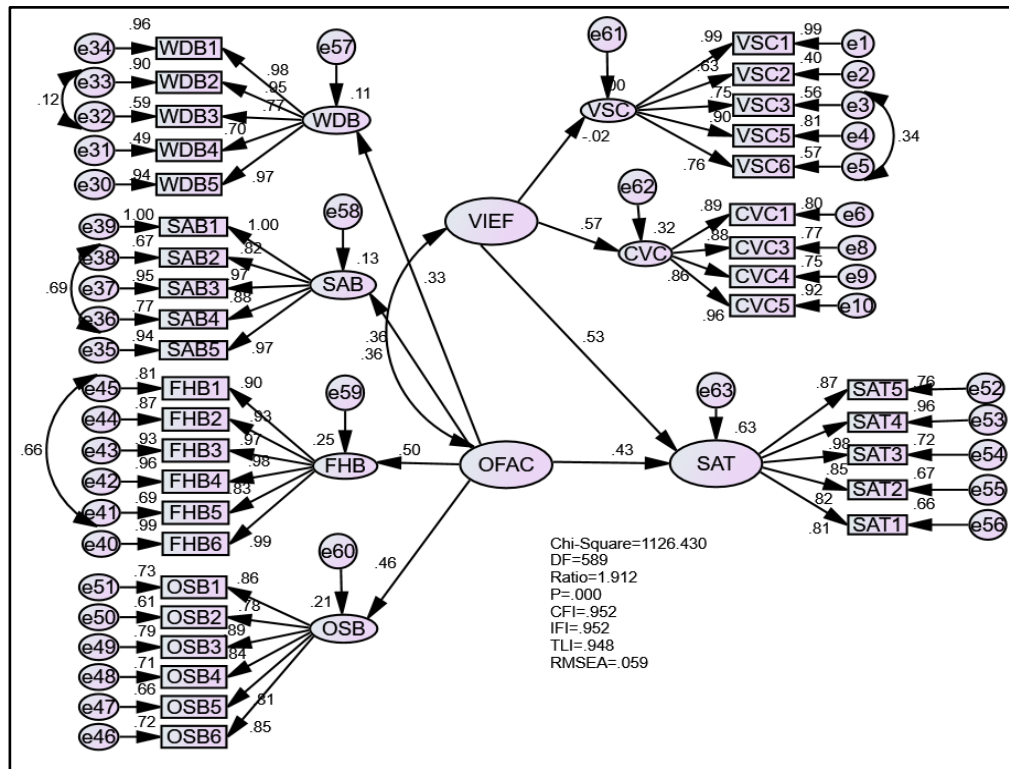

Figure 1: Structural Equation Model of Office and Window View Factors

Source: (Authors Field Work)

Conclusion

A major component of an effective organisation with a satisfied workforce is having a satisfactory physical environment. The significance of carrying out a study on the effect of office and window view factors on occupants' satisfaction is to promote social sustainability because a lot of time is spent in the office environment. Consequently, there is a need to provide a sustainable office environment for the occupants' well-being.

The Structural Equation Modelling tool used for the analysis was able to test the relationships between latent variables and their indicators simultaneously. The measurement model was used to check for the existing relationship linking latent variables and the observed variables, while the structural model displayed the relationship and path strength within the latent variables.

The results of this study are important steps towards establishing proper practices and guidelines for offices in the aspect of window views and the workspace arrangement. This study supplies additional information on occupants' satisfaction and their office environments for facility managers, architects, designers, landscape architects, and researchers. This study recommends that Building Designers should consider facing offices in the direction of natural and open scenes for maximum restorative effect on occupants'. This may likely boost occupants' satisfaction with their environment.

This research adds to the body of knowledge and it is an indicator that more interesting natural scenes should be intentionally created around office buildings to meet the needs of the occupants' psychologically for improved satisfaction levels.

Future studies could focus on other office layouts or the private sector, as this study dwells on government offices.

References

- Ali, A. S., Chua, S. J. L., & Lim, M. E. L. (2015). The effect of physical environment comfort on employees' performance in office buildings: A case study of three public universities in Malaysia. *Structural Survey*, 33(4–5), 294–308. <https://doi.org/10.1108/SS-02-2015-0012>
- Aries, M. B. C. C., Veitch, J. A., & Newsham, G. R. (2010). Windows, view, and office characteristics predict physical and psychological discomfort. *Journal of Environmental Psychology*, 30(4), 533–541. <https://doi.org/10.1016/j.jenvp.2009.12.004>
- Awang, Z. (2015). Chapter 6 : Data Analysis : Model Fit Analysis and Hypotheses Testing, 0(Byrne), 125–143.
- Bentler, P. M., & Bonett, D. G. (1980). Significance tests and goodness of fit in the analysis of covariance structures. *Psychological Bulletin*, 88(3), 588–606. <https://doi.org/10.1037/0033-2909.88.3.588>
- Bodin Danielsson, C., Wulff, C., & Westerlund, H. (2013). Is perception of leadership influenced by the office environment? *Journal of Corporate Real Estate*, 15(3), 194–212. <https://doi.org/10.1108/JCRE-03-2013-0008>
- Brundtland. (1987). UN WCED 1987 Brundtland Report.pdf.
- Chang, C. Y., & Chen, P. K. (2005). Human response to window views and indoor plants in the workplace. *HortScience*, 40(5), 1354–1359. <https://doi.org/10.21273/hortsci.40.5.1354>
- Charles, K., & Veitch, J. (2002). Environmental Satisfaction in Open-Plan Environments: 2. Effects of Workstation Size, Partition Height and Windows. Institute for Research in Construction National Research Council Canada Montreal Road, Ottawa, Ontario. <https://doi.org/10.4224/20378854>
- Chong, E. E., Nazim, A., & Ahmad, S. B. (2014). A comparison between Individual confirmatory factor analysis and pooled confirmatory factor analysis: *An analysis of library service quality, a case study at a public university in Terengganu. International Journal of Engineering Science and Innovative Technology*, 3(1), 110–116.
- Danielsson, B. C., & Bodin, L. (2008). Office type in relation to health, well-being, and job satisfaction among employees. *Environment and Behavior*, 40(5), 636–668. <https://doi.org/10.1177/0013916507307459>
- Danielsson, C. B., Bodin, L., Wulff, C., & Theorell, T. (2015). The relation between office type and workplace conflict: *A gender and noise perspective. Journal of Environmental Psychology*, 42, 161–171. <https://doi.org/10.1016/j.jenvp.2015.04.004>
- De Been, I., & Beijer, M. (2014). The influence of office type on satisfaction and perceived productivity support. *Journal of Facilities Management*, 12(2), 142–157. <https://doi.org/10.1108/JFM-02-2013-0011>
- Dogrusoy, I. T., & Tureyen, M. (2007). A field study on determination of preferences for windows in office environments. *Building and Environment*, 42(10), 3660–3668. <https://doi.org/10.1016/j.buildenv.2006.09.010>
- Fontenelle, M. R., & Bastos, L. E. G. (2014). The multicriteria approach in the architecture conception: Defining windows for an office building in Rio de Janeiro. *Building and Environment*, 74, 96–105. <https://doi.org/10.1016/j.buildenv.2014.01.005>

- Galasiu, A. D., & Veitch, J. A. (2006). Occupant preferences and satisfaction with the luminous environment and control systems in daylight offices: a literature review. *Energy and Buildings*, 38(7), 728–742. <https://doi.org/10.1016/j.enbuild.2006.03.001>
- Hartig, T., Mang, M., & Evans, G. W. (1991). Restorative Effects of Natural Environment Experiences. *Environment and Behavior*, 23(1), 3–26.
- Heerwagen, J. H., & Orians, G. H. (1986). Adaptations to windowlessness, a study of the use of visual decor.pdf. *Environment and Behavior*, 18(5), 623–639.
- Hellinga, H. (2013). Daylight and View, The influence of windows on the visual quality of indoor spaces (Vol. 53). <https://doi.org/10.1017/CBO9781107415324.004>
- Herzog, T. R., Kaplan, S., & Kaplan, R. (1976). The prediction of preference for familiar.pdf. *SAGE Social Sciences Collections*, 8(4), 627–645.
- Holmes-Smith, P. (2006). School Socio-Economic Density and its Effect on School Performance. Report for the New South Wales Department of Education and Training, (March), 1–39. Retrieved from <http://www.scseec.edu.au/>
- Hooper, D., Coughlan, J., & Mullen, M. R. (2008). Structural equation modelling: Guidelines for determining model fit. *Electronic Journal of Business Research Methods*, 6(1), 53–60. <https://doi.org/10.21427/D79B73>
- Hox, J. J., & Bechger, T. M. (1999). An introduction to structural equation modelling. *Studies in Health Technology and Informatics*, 213(November), 3–6. <https://doi.org/10.3233/978-1-61499-538-8-3>
- Kang, S., Ou, D., & Mak, C. M. (2017). The impact of indoor environmental quality on work productivity in university open-plan research offices. *Building and Environment*, 124, 78–89. <https://doi.org/10.1016/j.buildenv.2017.07.003>
- Kaplan, R. (1993). The role of nature in the context of the workplace. *Landscape and Urban Planning*, 26(1–4), 193–201. [https://doi.org/10.1016/0169-2046\(93\)90016-7](https://doi.org/10.1016/0169-2046(93)90016-7)
- Kaplan, S. (1995). The restorative benefits of nature: Toward an integrative framework. *Journal of Environmental Psychology*, 15(3), 169–182. [https://doi.org/10.1016/0272-4944\(95\)90001-2](https://doi.org/10.1016/0272-4944(95)90001-2)
- Konstantzos, I., Chan, Y. C., Seibold, J. C., Tzempelikos, A., Proctor, R. W., & Protzman, J. B. (2015). View clarity index: A new metric to evaluate the clarity of view through window shades. *Building and Environment*, 90, 206–214. <https://doi.org/10.1016/j.buildenv.2015.04.005>
- Küller, R., & Lindsten, C. (1992). Health and behaviour of children in classrooms with and without windows. *Journal of Environmental Psychology*, (12), 205–217.
- Kwon, M., Remøy, H., & Bogaard, M. Van Den. (2019). Influential design factors on occupant satisfaction with the indoor environment in workplaces. *Building and Environment*, 157(May), 356–365. <https://doi.org/10.1016/j.buildenv.2019.05.002>
- Leslie, R. P. (2003). Capturing the daylight dividend in buildings: Why and how? *Building and Environment*, 38(2), 381–385. [https://doi.org/10.1016/S0360-1323\(02\)00118-X](https://doi.org/10.1016/S0360-1323(02)00118-X)
- Lottrup, L., Stigsdotter, U. K., Meilby, H., & Claudi, A. G. (2015). The Workplace Window View: A Determinant of Office Workers' Work Ability and Job Satisfaction. *Landscape Research*, 40(1), 57–75. <https://doi.org/10.1080/01426397.2013.829806>
- Mangkuto, R. A., Rohmah, M., & Asri, A. D. (2016). Design optimisation for window size, orientation, and wall reflectance with regard to various daylight metrics and lighting energy demand: A case study of buildings in the tropics. *Applied Energy*, 164, 211–219. <https://doi.org/10.1016/j.apenergy.2015.11.046>
- Marty, C., Marty, C., Fontoynt, M., & Christoffersen, J. (2003). User assessment of visual comfort : Review of existing methods ECCO-build Contract N ° ENK-CT-2002-00656

- Report ECCO-Ingelux-200305-01 User assessment of visual comfort: Review of existing methods Author (s): Jan Wienold and Werner Osterhaus Date : Con, (November). <https://doi.org/10.13140/RG.2.1.4803.7843>
- Morrison, R. L., & Macky, K. A. (2016). The demands and resources arising from shared office spaces. *Applied Ergonomics*, 60, 103–115. <https://doi.org/10.1016/j.apergo.2016.11.007>
- O'Brien, W., & Gunay, H. B. (2014). The contextual factors contributing to occupants' adaptive comfort behaviours in offices - A review and proposed modelling framework. *Building and Environment*, 77, 77–87. <https://doi.org/10.1016/j.buildenv.2014.03.024>
- Ozdemir, A. (2010). The effect of window views' openness and naturalness on the perception of rooms' spaciousness and brightness: A visual preference study. *Scientific Research and Essays*, 5(16), 2275–2287. Retrieved from <http://www.academicjournals.org/journal/SRE/article-abstract/C49A20017716>
- Pallant, J. (2016). *For the SPSS Survival Manual A step by step guide to data analysis using IBM SPSS*. Open University Press.
- Salonen, H., Lahtinen, M., Lappalainen, S., Knibbs, L. D., Morawaska, L., & Reijula, K. (2014). The impact of windows, daylight and views of nature on health and wellbeing in healthcare facilities. *The International Sustainable Built Environment Conference*, (January), 28–30.
- Samani, S. A. (2015). The Impact of Personal Control over Office Workspace on Environmental Satisfaction and Performance. *Journal of Social Sciences and Humanities*, 1(3), 163–172. Retrieved from <http://www.aiscience.org/journal/jssh>
- Seddigh, A., Berntson, E., Bodin, C., & Westerlund, H. (2014). Concentration requirements modify the effect of office type on indicators of health and performance. *Journal of Environmental Psychology*, 38, 167–174. <https://doi.org/10.1016/j.jenvp.2014.01.009>
- Ulrich, R. S., Simons, R. F., Losito, B. D., Fiorito, E., Miles, M. A., & Zelson, M. (1991). Stress recovery during exposure to natural and urban environments. *Journal of Environmental Psychology*, 11(3), 201–230. [https://doi.org/10.1016/S0272-4944\(05\)80184-7](https://doi.org/10.1016/S0272-4944(05)80184-7)
- Van der Meiden, I., Kok, H., & Van der Velde, G. (2019). Nudging physical activity in offices. *Journal of Facilities Management*, 17(4), 317–330. <https://doi.org/10.1108/JFM-10-2018-0063>
- Yildirim, K., Akalin-Baskaya, A., & Celebi, M. (2007). The effects of window proximity, partition height, and gender on perceptions of open-plan offices. *Journal of Environmental Psychology*, 27(2), 154–165. <https://doi.org/10.1016/j.jenvp.2007.01.004>